

Responsive environments

by MYRON W. KRUEGER

*The University of Wisconsin
Madison, Wisconsin*

ABSTRACT

This paper introduces the concept of a responsive environment which perceives human behavior and responds with intelligent auditory and visual feedback. Several exhibits of responsive environments, implemented by the author, combining computer graphics, video projection and two-way video communication are described. VIDEOPLACE, an evolving exhibit which defines a conceptual telecommunication environment uniting geographically separated people in a common visual experience, is discussed at some length. Based on these examples a new art form of composed man-machine interaction is defined. Finally, practical applications are suggested for the fields of education, psychology and psychotherapy.

INTRODUCTION

Man-machine interaction is usually limited to a seated man poking at a machine with his fingers or perhaps waving a wand over a data tablet. Seven years ago, I was dissatisfied with such a restricted dialogue and embarked on research exploring more interesting ways for men and machines to relate. The result was the concept of a responsive environment in which a computer perceives the actions of those who enter and responds intelligently through complex visual and auditory displays.

Over a period of time the computer's displays establish a context within which the interaction occurs. It is within this context that the participant chooses his next action and anticipates the environment's response. If the response is unexpected, the environment has changed the context and the participant must reexamine his expectations. The experience is controlled by a composition which anticipates the participant's actions and flirts with his expectations.

This paper describes the evolution of these concepts from their primitive beginnings to my current project, VIDEOPLACE, which provides a general tool for devising many interactions. Based on these examples an interactive art form is defined and its promise identified. While the environments described were presented with aesthetic intent, their implications go beyond art. In the final section, applications in education, psychology and psychotherapy are suggested.

GLOWFLOW

In 1969, I became involved in the development of GLOWFLOW, a computer art project conceived by Dan Sandin, Jerry Erdman and Richard Venezky at the University of Wisconsin. It was designed in an atmosphere of encounter between art and technology. The viewer entered a darkened room in which glowing lines of light defined an illusory space (Figure 1). The display was accomplished by pumping phosphorescent particles through transparent tubes attached to the gallery walls. These tubes passed through opaque columns concealing lights which excited the phosphors. A pressure sensitive pad in front of each of the six columns enabled the computer to respond to footsteps by lighting different tubes or changing the sounds generated by a Moog synthesizer or the origin of these sounds. However, the artists' attitude toward the capacity for response was ambivalent. They felt that it was important that the environment respond, but not that the audience be aware of it. Delays were introduced between the detection of a participant and the computer's response so that the contemplative mood of the environment would not be destroyed by frantic attempts to elicit more responses.

While GLOWFLOW was quite successful visually, it succeeded more as a kinetic sculpture than as a responsive environment. However, the GLOWFLOW experience led me to a number of decisions:

1. Interactive art is potentially a richly composable medium quite distinct from the concerns of sculpture, graphic art or music.
2. In order to respond intelligently the computer should perceive as much as possible about the participant's behavior.
3. In order to focus on the relationships between the environment and the participants, rather than among participants, only a small number of people should be involved at a time.
4. The participants should be aware of how the environment is responding to them.
5. The choice of sound and visual response systems should be dictated by their ability to convey a wide variety of conceptual relationships.
6. The visual responses should not be judged as art nor

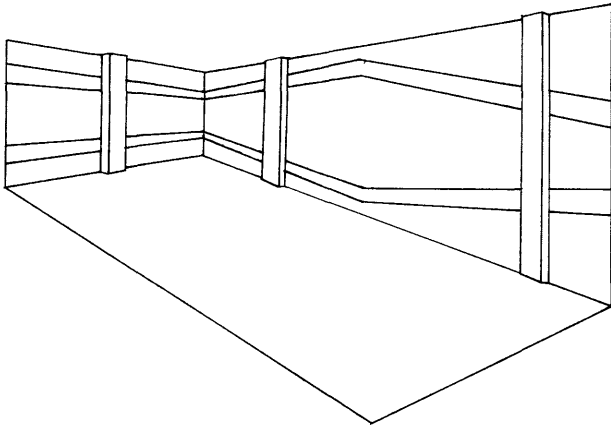

Figure 1—Glowflow tubes on gallery wall

the sounds as music. The only aesthetic concern is the quality of the interaction.

METAPLAY

Following the GLOWFLOW experience, I conceived and directed METAPLAY which was exhibited in the Memorial Union Gallery of the University of Wisconsin for a month in 1970. It was supported by the National Science Foundation, the Computer Science Department, the Graduate School and the loan of a PDP-12 by Digital Equipment Corporation.

METAPLAY'S focus reflected my reactions to GLOWFLOW. Interaction between the participants and the environment was emphasized; the computer was used to facilitate a unique real-time relationship between the artist and the participant. An 8' by 10' rear-projection video screen dominated the gallery. The live video image of the viewer and a computer graphic image drawn by an artist, who was in another building, were superimposed on this screen. Both the viewer and the artist could respond to the resulting image.

Hardware

The image communications (Figure 2) started with an analogue data tablet which enabled the artist to draw or write on the computer screen. The person doing the drawing did not have to be an artist, but the term is used for convenience. One video camera, in the Computer Center, was aimed at the display screen of the Adage Graphic Display Computer. A second camera, a mile away in the gallery, picked up the live image of people in the room. A television cable transmitted the video computer image from the Computer Center to the gallery and the two signals were mixed so that the computer image overlaid the live image. The composite image was projected on the 8' x 10' screen in the gallery and was simultaneously transmitted back to the Computer Center where it was displayed on a video monitor providing feedback for the artist.

The artist could draw on the Adage screen using a data tablet. By using function switches, potentiometers and the teletype keyboard the pictures could be rapidly modified or the mode of drawing itself altered. In addition to the effects of simple drawings, the image could be moved around the screen, image size could be controlled and the picture could be repeated up to ten times on the screen displaced by variable X, Y and size increments. A tail of a fixed number of line segments could be drawn allowing the removal of a segment at one end while another was added at the opposite end. An image could be rotated in 3-space under control of the pen. Although this was not true rotation, the visual effect was similar. A simple set of transformations under potentiometer and tablet control yielded apparent animation of people's outlines. Finally, previously defined images could be recalled or exploded. While it might seem that the drawing could be done without a computer, the ability to rapidly erase, recall and transform images required considerable processing and created a far more powerful means of expression than pencil and paper could provide.

Interaction

These facilities provided a rich repertoire for an unusual dialogue. The artist could draw pictures on the participants' images or communicate directly by writing words on the screen (Figure 3). He could induce people to play a game like Tic-Tac-Toe or play with the act of drawing, starting to draw one kind of picture only to have it transformed into another by interpolation.

Live graffiti

One interaction derived from the artist's ability to draw on the image of the audience. He could add graffiti-like features or animate a drawn outline of a person so that it appeared to dance to the music in the gallery. The artist tried various approaches to involve people in the interaction. Failing to engage one person, he would seek someone more responsive.

It was important to involve the participants in the act of drawing. However, the electronic wand designed for this purpose did not work reliably. What evolved was a serendipitous solution. One day as I was trying to draw on a student's hand, he became confused and moved it. When I erased my scribbles and started over, he moved his hand again. He did this repeatedly until it became a game. Finally, it degenerated to the point where I was simply tracking the image of his hand with the computer line. In effect, by moving his hand he could draw on the screen before him.

The relationship established with this participant was developed as one of the major themes of METAPLAY. It was repeated and varied until it became an aesthetic medium in itself. With each person we involved in this way, we tried to preserve the pleasure of the original discovery. After playing some graffiti games with each group that

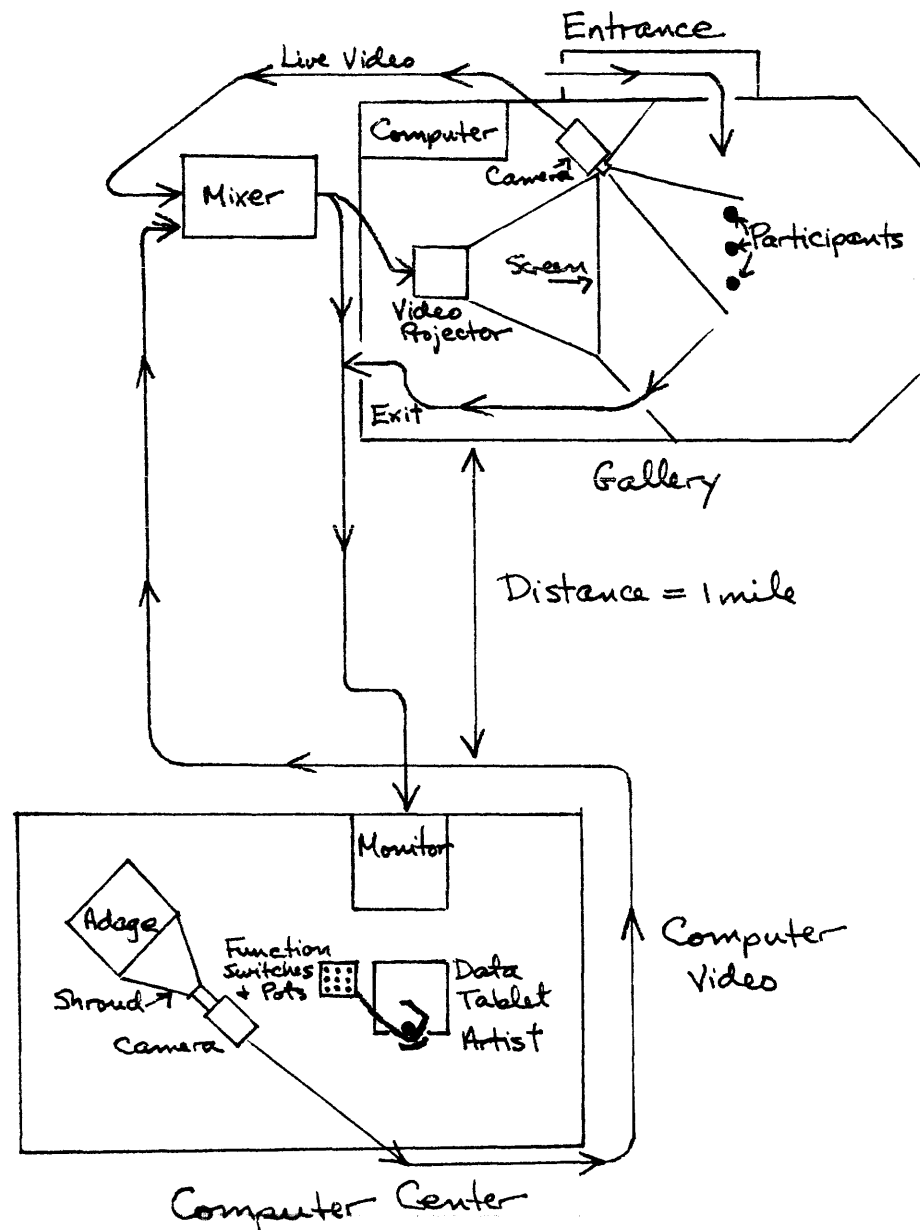

Figure 2—Metaplay communications

entered, we would focus on a single individual and draw around the image of his hand. After an initial reaction of blank bewilderment, the self-conscious person would make a nervous gesture. The computer line traced the gesture. A second gesture, followed by the line was the key to discovery. One could draw on the video screen with his finger! Others in the group, observing this phenomenon, would want to try it too. The line could be passed from one person's finger to another's. Literally hundreds of interactive vignettes developed within this simple communication channel.

Drawing by this method was a rough process. Pictures of any but the simplest shapes were unattainable. This was mainly because of the difficulty of tracking a person's

finger. Happily, neither the artist nor the audience were concerned about the quality of the drawings. What was exciting was interacting in this novel way through a man-computer-video link spanning a mile.

PSYCHIC SPACE

The next step in the evolution of the responsive environment was PSYCHIC SPACE, which I designed and exhibited in the Memorial Union Gallery during May and June of 1971. It was implemented with the help of my students, the Computer Science Department and a National Science Foundation grant in Complex Information Processing.

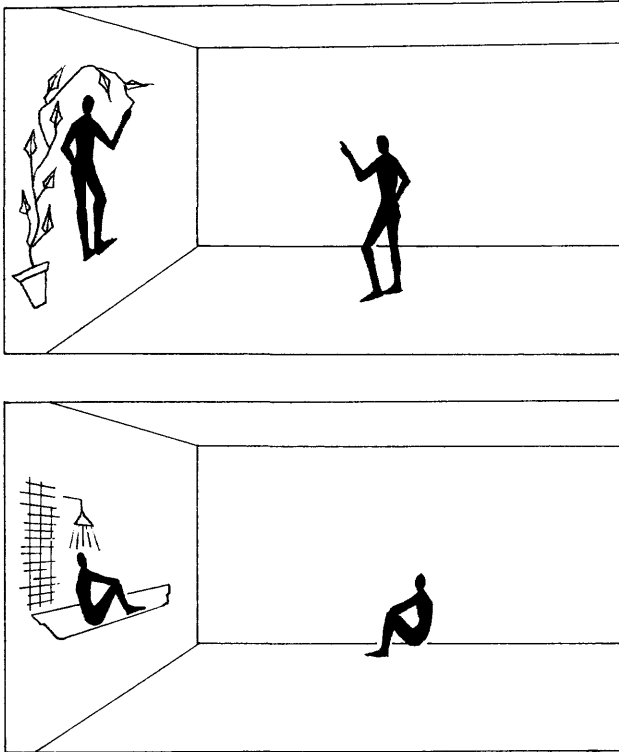

Figure 3—Metaplay drawing

PSYCHIC SPACE was both an instrument for musical expression and a richly composed, interactive, visual experience. Participants could become involved in a softshoe duet with the environment, or they could attempt to match wits with the computer by walking an unpredictable maze projected on an 8' × 10' video screen.

Hardware

A PDP-11 had direct control of all sensing and sound in the gallery. In addition, it communicated with the Adage AGT-10 Graphic Display Computer at the Computer Center (Figure 4). The Adage image was transmitted over video cable to the gallery where it was rear-projected on the 8' × 10' screen. The participant's position on the floor was the basis for each of the interactions. The sensing was done by a 16' × 24' grid of pressure switches, constructed in 2' × 4' modules, each containing eight switches (Figure 5). Since they were electronically independent, the system was able to discriminate among individuals if several were present. This independence made it easy for the programming to ignore a faulty switch until its module was replaced or repaired. Since there were 16 bits in the input words of the PDP-11, it was natural to read the 16 switches in each row across the room in parallel (Figure 6). Digital circuitry was then used to scan the 24 rows under computer control.

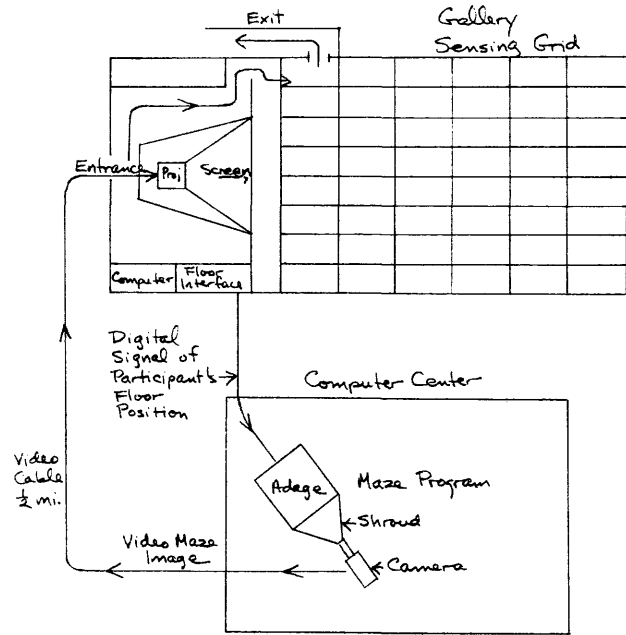

Figure 4—Data and video communication for psychic space

Input and interaction

Since the goal was to encourage the participants to express themselves through the environment, the program automatically responded to the footsteps of people entering the room with electronic sound. We experimented with a number of different schemes for actually generating the sounds based on an analysis of peoples' footsteps. In sampling the floor 60 times per second we discovered that a single footstep consisted of as many as four discrete events: lifting the heel, lifting the toe, putting the heel down and putting the ball of the foot down. The first two were dubbed the "unfootstep." We could respond to each footstep or unfootstep as it occurred, or we could respond to the person's average position. A number of response schemes were tried, but the most pleasing was to start each

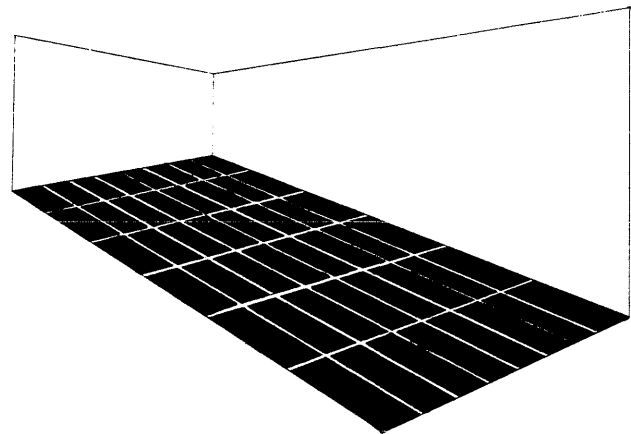

Figure 5—Flooring sensing modules in psychic space

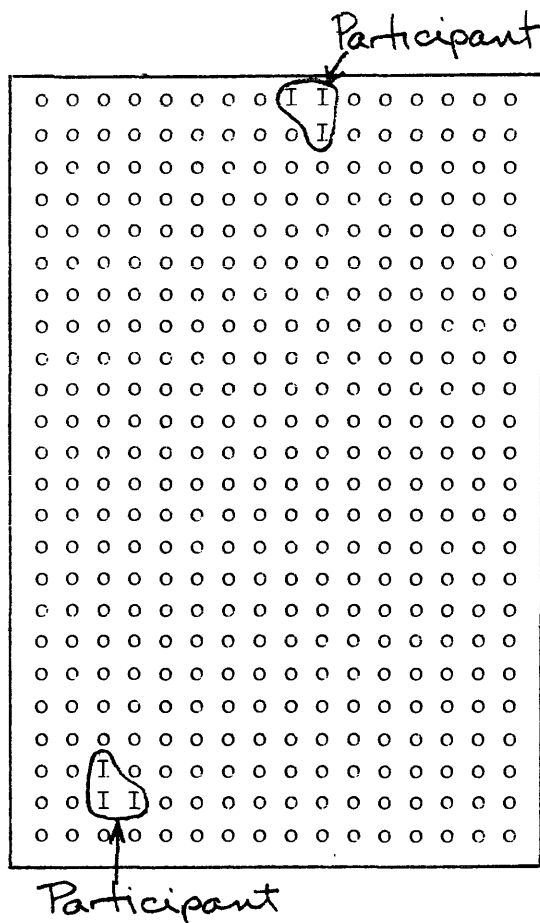

Figure 6—Participants' feet are seen by the computer as ones in a field of zeroes

tone only when a new switch was stepped on and then to terminate it on the next "unfootstep." Thus it was possible to get silence by jumping, or by lifting one foot, or by putting both feet on the same switch.

Typical reaction to the sounds was instant understanding, followed by a rapid-fire sequence of steps, jumps and rolls. This phase was followed by a slower more thoughtful exploration of the environment in which more subtle and interesting relationships could be developed. In the second phase, the participant would discover that the room was organized with high notes at one end and low notes at the other. After a while, the keyboard was abruptly rotated by 90 degrees.

After a longer period of time an additional feature came into play. If the computer discovered that a person's behavior was characterized by a short series of steps punctuated by relatively long pauses, it would use the pause to establish a new kind of relationship. The sequence of steps was responded to with a series of notes as before; however, during the pause the computer would repeat these notes again. If the person remained still during the pause, the computer assumed that the relationship was understood. The next sequence of steps was echoed at a noticea-

bly higher pitch. Subsequent sequences were repeated several times with variations each time. This interaction was experimental and extremely difficult to introduce clearly with feedback alone, i.e., without explicit instructions. The desire was for a man-machine dialogue resembling the guitar duel in the film "Deliverance."

MAZE—A COMPOSED ENVIRONMENT

The maze program focused on the interaction between one individual and the environment. The participant was lured into attempting to navigate a projected maze. The intrigue derived from the maze's responses, a carefully composed sequence of relations designed to constitute a unique and coherent experience.

Hardware

The maze itself was not programmed on the PDP-11, but on the Adage located a mile away in the Computer Center. The PDP-11 transmitted the participant's floor coordinates across an audio cable to the Adage. The data was transmitted asynchronously as a serial bit stream of varying pulse widths. The Adage generated the maze image which was picked up by a TV camera and transmitted via a video cable back to the Union where it was rear-screen projected to a size of 8' × 10'.

Interaction

The first problem was simply to educate the person to the relationships between the floor and the screen. Initially, a diamond with a cross in it representing the person's position appeared on the screen. Physical movement in the room caused the symbol to move correspondingly on the screen. As the participant approached the screen, the symbol moved up. As he moved away, it moved down. The next step was to induce the person to move to the starting point of the maze, which had not yet appeared on the screen (Figure 7). To this end, another object was placed on the screen at the position which would be the starting point of the maze. The viewer unavoidably wondered what would happen if he walked his symbol to the object. The arrival of his symbol at the starting point caused the object to vanish and the maze to appear. Thus confronted with the maze, no one questioned the inevitability of walking it.

Software boundaries

Since there was no physical constraints in the gallery, the boundaries of the maze had to be enforced by the computer. Each attempt to violate a boundary was foiled by one of many responses in the computer's repertoire. The computer could move the line, stretch it elastically, or move the whole maze. The line could disappear, seemingly removing the barrier, except that the rest of the maze would change

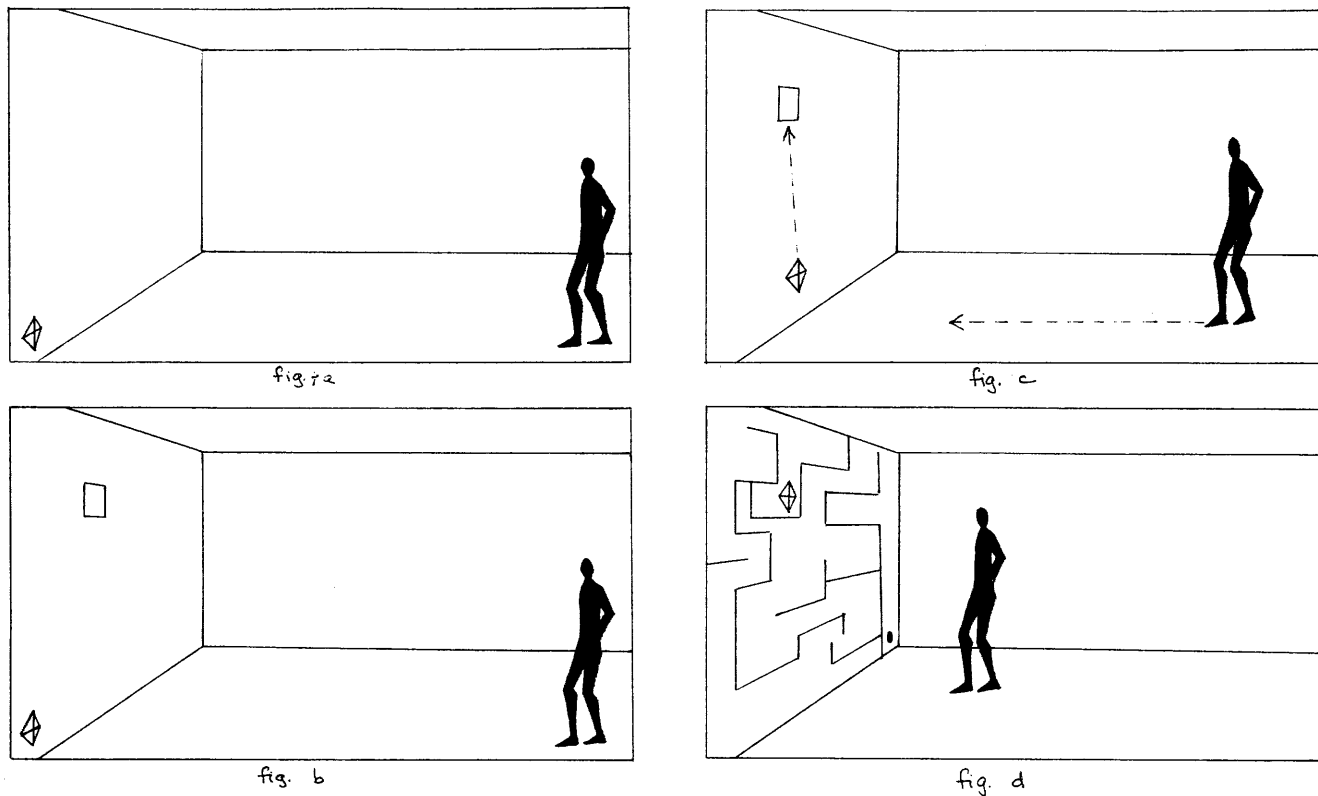

Figure 7—Composed environment-Maze

simultaneously so no advantage was gained. In addition, the symbol representing the person could split in half at the violated boundary, with one half held stationary while the other half, the alter ego, continued to track movement. However, no progress could be made until the halves of the symbol were reunited at the violated boundary.

Even when the participant was moving legally, there were changes in the program contingent upon his position. Several times, as the goal was approached, the maze changed to thwart immediate success. Or, the relationship between the floor and the maze was altered so that movements that once resulted in vertical motion, now resulted in horizontal motion. Alternatively, the symbol representing the participant could remain stationary while the maze moved.

Ultimately, success was not allowed. When reaching the goal seemed imminent, additional boundaries appeared in front of and behind the symbol, boxing it in. At this point, the maze slowly shrank to nothing. While the goal could not be reached, the composed frustration made the route interesting.

Experience

The maze experience conveyed a unique set of feelings. The video display space created a sense of detachment

enhanced by the displaced feedback; movement on the horizontal plane of the floor translated onto the vertical plane of the screen. The popular stereotype of dehumanizing technology seemed fulfilled. However, the maze idea was engaging and people became involved willingly. The lack of any other sensation focused attention completely on this interaction. As the experience progressed, their perception of the maze changed. From the initial impression that it was a problem to solve, they moved to the realization that the maze was a vehicle for whimsy, playing with the concept of a maze and poking fun at their compulsion to walk it.

VIDEOPPLACE

For the past two years I have been working on a project called VIDEOPPLACE, under the aegis of the Space Science and Engineering Center of the University of Wisconsin. This work is funded by the National Endowment for the Arts and the Wisconsin Arts Board. A preliminary version was exhibited at the Milwaukee Art Center for six weeks beginning in October 1975. The development of VIDEOPPLACE is still under way and several more years will be required before its potential is fully realized both in terms of implementing the enabling hardware and exploring its compositional possibilities.

VIDEOPLACE is a conceptual environment with no physical existence. It unites people in separate locations in a common visual experience, allowing them to interact in unexpected ways through the video medium. The term VIDEOPLACE is based on the premise that the act of communication creates a place that consists of all the information that the participants share at that moment. When people are in the same room, the physical and communication places are the same. When the communicants are separated by distance, as in a telephone conversation, there is still a sense of being together although sight and touch are not possible. By using television instead of telephone, VIDEOPLACE seeks to augment this sense of place by including vision, physical dimension and a new interpretation of touch.

VIDEOPLACE consists of two or more identical environments which can be adjacent or hundreds of miles apart. In each environment, a single person walks into a darkened room where he finds himself confronted by an 8' x 10' rear-view projection screen. On the screen he sees his own life-size image and the image of one or more other people. This is surprising in itself, since he is alone in the room (Figure 8). The other images are of people in the other environments. They see the same composite image on their screens. The visual effect is of several people in the same room. By moving around their respective rooms, thus moving their images, the participants can interact within the limitations of the video medium.

It is these apparent limitations that I am currently working to overcome. When people are physically together, they

can talk, move around the same space, manipulate the same objects and touch each other. All of these actions would appear to be impossible within the VIDEOPLACE. However, the opposite is true. The video medium has the potential of being more rich and variable in some ways, than reality itself.

It would be easy to allow the participants to talk, although I usually preclude this, to force people to focus on the less familiar kinds of interaction that the video medium provides. A sense of dimension can be created with the help of computer graphics, which can define a room or another spatial context within which the participants appear to move around. Graphics can also furnish this space with artificial objects and inhabit it with imaginary organisms. The sense of touch would seem to be impossible to duplicate. However, since the cameras see each person's image in contrast to a neutral background, it is easy to digitize the outline and to determine its orientation on the screen (Figure 9). It is also easy to tell if one person's image touches another's, or if someone touches a computer graphic object. Given this information the computer can make the sense of touch effective. It can currently respond with sounds when two images touch and will ultimately allow a person's image to pick up a graphic object and move it about the screen.

While the participants' bodies are bound by physical laws such as gravity, their images could be moved around the screen, shrunk, rotated, colored and keyed together in arbitrary ways. Thus, the full power of video processing

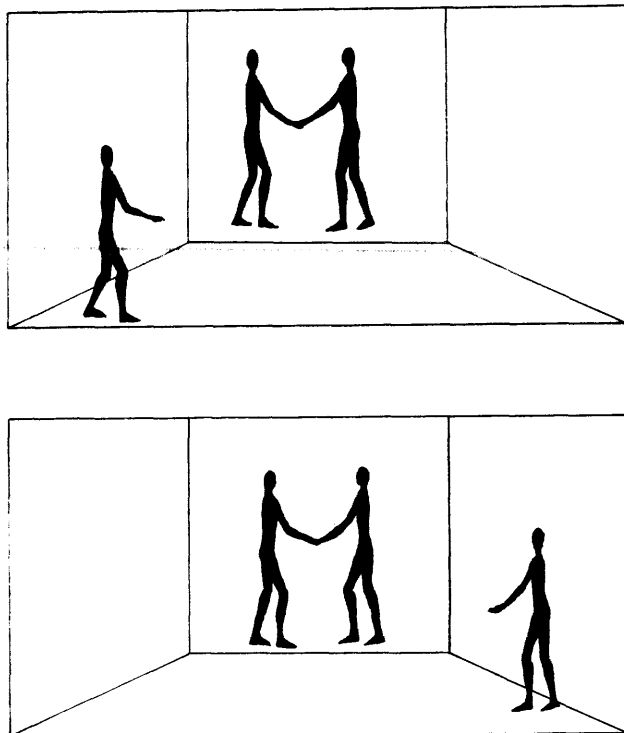

Figure 8—Videoplace

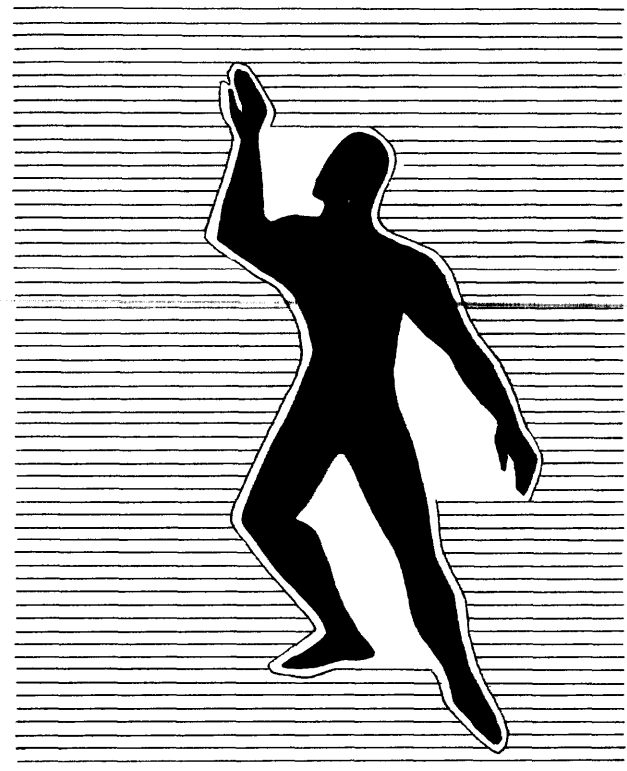

Figure 9—The video outline sensor

could be used to mediate the interaction and the usual laws of cause and effect replaced with alternatives composed by the artist.

The impact of the experience will derive from the fact that each person has a very proprietary feeling towards his own image. What happens to his image happens to him. In fact, when one person's image overlaps another's, there is a psychological sensation akin to touch. In VIDEOPLACE, this sensation can be enhanced in a number of ways. One image can occlude the other. Both images can disappear where they intersect. Both images can disappear except where they intersect. The intersection of two images can be used to form a window into another scene so two participants have to cooperate to see a third.

VIDEOPLACE need not involve more than one participant. It is quite possible to create a compelling experience for one person by projecting him into this imaginary domain alone. In fact the hardware/software system underlying VIDEOPLACE is not conceived as a single work but as a general facility for exploring all the possibilities of the medium to be described next.

RESPONSE IS THE MEDIUM

The environments described suggest a new art medium based on a commitment to real-time interaction between men and machines. The medium is comprised of sensing, display and control systems. It accepts inputs from or about the participant and then outputs in a way he can recognize as corresponding to his behavior. The relationship between inputs and outputs is arbitrary and variable, allowing the artist to intervene between the participant's action and the results perceived. Thus, for example, the participant's physical movement can cause sounds or his voice can be used to navigate a computer defined visual space. It is the composition of these relationships between action and response that is important. The beauty of the visual and aural response is secondary. Response is the medium!

The distinguishing aspect of the medium is, of course, the fact that it responds to the viewer in an interesting way. In order to do this, it must know as much as possible about what the participant is doing. It cannot respond intelligently if it is unable to distinguish various kinds of behavior as they occur.

The environment might be able to respond to the participant's position, voice volume or pitch, position relative to prior position or the time elapsed since the last movement. It could also respond to every third movement, the rate of movement, posture, height, colors of clothing or time elapsed since the person entered the room. If there were several people in the room, it might respond to the distance separating them, the average of their positions or the computer's ability to resolve them, i.e., respond differently when they are very close together.

In more complex interactions like the maze, the computer can create a context within which the interaction occurs. This context is an artificial reality within which the artist has complete control of the laws of cause and effect.

Thus the actions perceived by the hardware sensors are tested for significance within the current context. The computer asks if the person has crossed the boundary in the maze or has touched the image of a particular object. At a higher level the machine can learn about the individual and judge from its past experience with similar individuals just which responses would be most effective.

Currently, these systems are constrained by the total inability of the computer to make certain very useful and for the human, very simple perceptual judgments, such as whether a given individual is a man or a woman or is young or old. The perceptual system will define the limits of meaningful interaction, for the environment cannot respond to what it cannot perceive. To date the sensing systems have included pressure pads, ultrasonics and video digitizing.

As mentioned before, the actual means of output are not as important in this medium as they would be if the form were conceived as solely visual or auditory. In fact, it may be desirable that the output not qualify as beautiful in any sense, for that would distract from the central theme: the relationship established between the observer and the environment. Artists are fully capable of producing effective displays in a number of media. This fact is well known and to duplicate it produces nothing new. What is not known and remains to be tested is the validity of a responsive aesthetic.

It is necessary that the output media be capable of displaying intelligent, or at least composed reactions, so that the participant knows which of his actions provoked it and what the relationship of the response is to his action. The purpose of the displays is to communicate the relationships that the environment is trying to establish. They must be capable of great variation and fine control. The response can be expressed in light, sound mechanical movement, or through any means that can be perceived. So far computer graphics, video generators, light arrays and sound synthesizers have been used.

CONTROL AND COMPOSITION

The control system includes hardware and software control of all inputs and outputs as well as processing for decisions that are programmed by the artist. He must balance his desire for interesting relationships against the commitment to respond in real-time. The simplest responses are little more than direct feedback of the participant's behavior, allowing the environment to show off its perceptual system. But far more sophisticated results are possible. In fact, a given aggregation of hardware sensors, displays and processors can be viewed as an instrument which can be programmed by artists with differing sensitivities to create completely different experiences. The environment can be thought of in the following ways:

1. An entity which engages the participant in a dialogue. The environment expresses itself through light and sound while the participant communicates with physi-

cal motion. Since the experience is an encounter between individuals, it might legitimately include greetings, introductions and farewells—all in an abstract rather than literal way. The problem is to provide an interesting personality for the environment.

2. A personal amplifier. One individual uses the environment to enhance his ability to interact with those within it. To the participants the interaction might appear similar to that described above. The result would be limited by the speed of the artist's response but improved by his sensitivity to the participants' moods. The live drawing interaction in METAPLAY could be considered an example of this approach.
3. An environment which has sub-environments with different response relationships. This space could be inhabited by artificial organisms defined either visually or with sound. These creatures can interact with the participants as they move about the room.
4. An amplifier of physical position in a real or artificially generated space. Movements around the environment would result in much larger apparent movements in the visually represented space. A graphic display computer can be used to generate a perspective view of a modelled space as it would appear if the participant were within it. Movements in the room would result in changes in the display, so that by moving only five feet within the environment, the participant would appear to have moved fifty feet in the display. The rules of the modelled space can be totally arbitrary and physically impossible, e.g. a space where objects recede when you approach them.
5. An instrument which the participants play by moving about the space. In PSYCHIC SPACE the floor was used as a keyboard for a simple musical instrument.
6. A means of turning the participant's body into an instrument. His physical posture would be determined from a digitized video image and the orientation of the limbs would be used to control lights and sounds.
7. A game between the computer and the participant. This variation is really a far more involving extension of the pinball machine, already the most commercially successful interactive environment.
8. An experimental parable where the theme is illustrated by the things that happen to the protagonist—the participant. Viewed from this perspective, the maze in PSYCHIC SPACE becomes pregnant with meaning. It was impossible to succeed, to solve the maze. This could be a frustrating experience if one were trying to reach the goal. If, on the other hand, the participant maintained an active curiosity about how the maze would thwart him next, the experience was entertaining. Such poetic composition of experience is one of the most promising lines of development to be pursued with the environments.

IMPLICATIONS OF THE ART FORM

For the artist the environment augurs new relationships with his audience and his art. He operates at a metalevel.

The participant provides the direct performance of the experience. The environmental hardware is the instrument. The computer acts much as an orchestra conductor controlling the broad relationships while the artist provides the score to which both performer and conductor are bound. This relationship may be a familiar one for the musical composer, although even he is accustomed to being able to recognize one of his pieces, no matter who is interpreting it. But the artist's responsibilities here become even broader than those of a composer who typically defines a detailed sequence of events. He is composing a sequence of possibilities, many of which will not be realized for any given participant who fails to take the particular path along which they lie.

Since the artist is not dedicated to the idea that his entire piece be experienced he can deal with contingencies. He can try different approaches, different ways of trying to elicit participation. He can take into account the differences among people. In the past, art has often been a one-shot, hit-or-miss proposition. A painting could accept any attention paid it, but could do little to maintain interest once it had started to wane. In an environment the loss of attention can be sensed as a person walks away. The medium can try to regain attention and upon failure, try again. The piece has a second strike capability. In fact it can learn to improve its performance, responding not only to the moment but also to the entire history of its experience.

In the environment, the participant is confronted with a completely new kind of experience. He is stripped of his informed expectations and forced to deal with the moment in its own terms. He is actively involved, discovering that his limbs have been given new meaning and that he can express himself in new ways. He does not simply admire the work of the artist; he shares in its creation. The experience he achieves will be unique to his movements and may go beyond the intentions of the artist or his understanding of the possibilities of the piece.

Finally, in an exciting and frightening way, the environments dramatize the extent to which we are savages in a world of our own creation. The layman has extremely little ability to define the limits of what is possible with current technology and so will accept all sorts of cues as representing relationships which in fact do not exist. The constant birth of such superstitions indicates how much we have already accomplished in mastering our natural environment and how difficult the initial discoveries must have been.

APPLICATIONS

The responsive environment is not limited to aesthetic expression. It is a potent tool with applications in many fields. VIDEOPLACE clearly generalizes the act of telecommunication. It creates a form of communication so powerful that two people might choose to meet visually, even if it were possible for them to meet physically. While it is not immediately obvious that VIDEOPLACE is the optimum means of telecommunication, it is reasonably fair to say that it provides an infinitely richer interaction than

Picturephone allows. It broadens the range of possibilities beyond current efforts at teleconferencing. Even in its fetal stage, VIDEOPLACE is far more flexible than the telephone is after one hundred years of development. At a time when the cost of transportation is increasing and fiber optics promise to reduce the cost of communication, it seems appropriate to research the act of communication in an intuitive sense as well as in the strictly scientific and problem-solving approaches that prevail today.

EDUCATION

Responsive environments have tremendous potential for education. Our entire educational system is based on the assumption that thirty children will sit still in the same room for six hours a day and learn. This phenomenon has never been observed in nature and it's the exception in the classroom where teachers are pitted against children's natural desire to be active. The responsive environments offer a learning situation in which physical activity is encouraged. It is part of the process. An environment like VIDEOPLACE has an additional advantage. It gives the child a life-size physically identical alter ego who takes part in composed learning adventures on the video screen. In a fully developed VIDEOPLACE the size and position of the child's image on the screen would be independent of actual location in the room. In an interactive Sesame Street a child would be mesmerized as his own miniaturized image was picked up by a giant Big Bird (Figure 10). Conversely he would be delighted if the scales were reversed and he were able to pick up the image of a tiny adult teacher who spoke to him from his hand. The most overworked educational cliché, "experience is the best teacher," would have new meaning in this context. The environments provide an experience which can be composed and condensed to demonstrate an educational point.

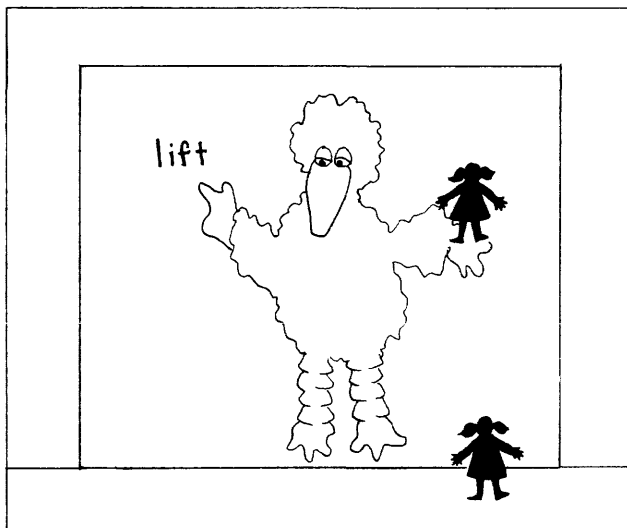

Figure 10—Interactive sesame street

While it is easy to generate examples of how the environments can be used to teach traditional subjects, their significance does not lie only in their ability to automate traditional teaching. More important, they may revolutionize what we teach as well as how we teach. Since the environments can define interesting relationships and change them in complex ways, it should be possible to create interactions which enrich the child's conceptual experience. This would provide the child with more powerful intellectual structures within which to organize the specific information he will acquire later. The goal would be to sophisticate the child, not to feed him facts.

PSYCHOLOGY

Since the environments can monitor the participants' actions and respond with visual and auditory feedback, it is natural to consider their application to the study of human behavior. The use of the computer allows an experimenter to generate patterns and rhythms of stimuli and reinforcers. In addition, the ability to deal with gross physical behavior would suggest new experimental directions. For instance, perception could be studied as part of physical behavior and not as a sedentary activity distinct from it. Also, an environment like VIDEOPLACE is very general. The same aggregate of hardware and software could be programmed to control a broad range of experiments. The scheduling of different experiments could be interspersed because only the software would have to be changed.

Since the university students used as subjects in many experiments are quite sophisticated about the concerns of psychologists, what is often being studied is the self-conscious behavior of people who know they are in an experiment and are trying to second-guess it. On the other hand, environments open to the public offer a source of spontaneous behavior. It is quite easy for the computer to take statistics without interfering with the experience. Or, interactions can be composed to test specific experimental hypotheses.

PSYCHOTHERAPY

It is also worth considering the application of responsive environments to psychotherapy. Perhaps most important for a psychotherapist is the ability of the environment to evoke and expand behavior. We have found in the past that people alone in a dark room often become very playful and flamboyant—far more so than they are in almost any other situation. Since the environment is kept dark, the patient has a sense of anonymity; he can do things that he might not do otherwise. The fact that he is alone in the dark serves to protect him both from his image of himself and from his fear of other people. The darkness also is a form of sensory deprivation which might prevent a patient from withdrawing. If he is to receive any stimulation at all, it must be from acting within the environment. Once he acts, he can be reinforced for continuing to act.

In the event that the subject refuses to act, the environment can focus on motions so small as to be unavoidable and respond to these and as time goes by encourage them, slowly expanding them into larger behavior, ultimately leading the patient to extreme or cathartic action.

In certain situations the therapist essentially programs himself to become mechanical and predictable, providing a structure that the patient can accept which can be expanded slowly beyond the original contract. It is possible that it would be easier to get a patient to trust a mechanical environment and completely mechanized therapy. Once the patient was acting and trusting within the environment, it would be possible to slowly phase in some elements of change, to generalize his confidence. As time went by, human images and finally human beings might be added. At this point, the patient could venture from his responsive womb, returning to it as often as needed.

CONCLUSION

The responsive environment has been presented as the basis for a new aesthetic medium based on real-time interaction between men and machines. In the long range it augurs a new realm of human experience, artificial realities which seek not to simulate the physical world but to define

arbitrary, abstract and otherwise impossible relationships between action and result. In addition, it has been suggested that the concepts and tools of the responsive environments can be fruitfully applied in a number of fields.

What perhaps has been obscured is that these concepts are the result of a personal need to understand and express the essence of the computer in humanistic terms. An earlier project to teach people how to use the computer was abandoned in favor of exhibits which taught people about the computer by letting them experience it. METAPLAY, PSYCHIC SPACE and VIDEOPLACE were designed to communicate an affirmative vision of technology to the lay public. This level of education is important, for our culture cannot continue if a large proportion of our population is hostile to the tools that define it.

We are incredibly attuned to the idea that the sole purpose of our technology is to solve problems. It also creates concepts and philosophy. We must more fully explore these aspects of our inventions, because the next generation of technology will speak to us, understand us, and perceive our behavior. It will enter every home and office and intercede between us and much of the information and experience we receive. The design of such intimate technology is an aesthetic issue as much as an engineering one. We must recognize this if we are to understand and choose what we become as a result of what we have made.

